

**P510/2**  
**PHYSICS**  
**PAPER 2**  
AUGUST 2019  
2 ½ HOURS



**MASAKA DIOCESAN EXAMINATIONS BOARD**

Uganda Advanced Certificate of Education

JOINT MOCK EXAMINATION 2019

**PHYSICS**

**PAPER 2**

**2 ½ HOURS**

**INSTRUCTIONS TO CANDIDATES:**

- Answer five questions, taking at least one from each of the sections A, B, C and D but not more than one question should be chosen from either section A or B.
- Assume where necessary  
Acceleration due to gravity of  $= 9.81 \text{ms}^{-1}$   
Speed of light in a vacuum C  $= 3.0 \times 10^8 \text{ms}^{-1}$   
The constant  $\frac{1}{4\pi\epsilon_0}$   $= 9.0 \times 10^9 \text{F}^{-1}\text{m}^{-1}$   
Permittivity of free space  $\epsilon_0$   $= 8.85 \times 10^{-12} \text{Fm}^{-1}$   
Permeability of free space  $\mu_0$   $= 4.0\pi \times 10^{-7} \text{Hm}$

## SECTION A

1. (a) (i) Define reflection of light. (1 marks)  
(ii) Explain why thick plane mirror forms Multiple images. (3 marks)
  - (b) (i) Draw a ray diagram showing how a concave mirror can form a magnified virtual image. (2 marks)  
(ii) By using the diagram in (b) (i) derive mirror formula. (4 marks)
  - (c) A small convex mirror is placed 60cm from the pole and on the axis of a large concave mirror of a radius of curvature 200cm. The position of the convex mirror is such that a real image of distant object is formed in the plane of a hole drilled through the concave mirror at its pole. Find the radius of curvature of the convex mirror. (4 marks)
  - (d) Describe the experiment to determine the focal length of a convex mirror using plane mirror. (5 marks)
  - (e) State advantages of reflecting telescope over the refracting type. (1 mark)
2. (a) Explain what is meant by reversibility of light in convex lens. (2 marks)
  - (b) (i) Describe how the refractive index of a liquid can be determined by using concave mirror. (4 marks)  
(ii) Derive the expression for refractive index of a liquid in (b) (i) above. (4 marks)
  - (c) A ray of yellow light is incident at angle of  $40^{\circ}$  on a piece of crown glass whose faces are parallel and 244mm apart. If the refractive index of glass for yellow light is 1.574, find the transverse displacement of the ray of light. (4 marks)
  - (d) (i) The objective and eye piece of an astronomical telescope have focal lengths of 75.0cm and 2.5cm respectively. Find the eye ring position if final image is formed 25cm from the eye piece. (4 marks)  
(ii) Explain why chromatic aberration is not observed in simple microscope. (2 marks)

## SECTION B

3. (a) Define the following as applied to wave.  
(i) Harmonic  
(ii) Fundamental note (2 marks)

- (b) Explain why the amplitude of the wave decreases as a wave spreads away from the source. (2 marks)
- (c) (i) Explain how a standing wave is formed in a closed pipe. (3 marks)  
(ii) A progressive wave  $y = a \sin 2\pi \left( \frac{t}{T} + \frac{x}{\lambda} \right)$  is reflected at a barrier to interfere with the incoming wave. Show that the resultant wave is a stationary wave. (4 marks)
- (d) Describe an experiment to show that sound waves exhibit interference by using loud speaker. (4 marks)
- (f) Calculate for the frequency of the beats heard by a stationary observer when a source of sound of frequency 80Hz is receding him with a speed of  $5.0\text{ms}^{-1}$  towards a vertical wall. (5 marks)  
(Take speed of sound in air as  $340\text{ms}^{-1}$ )
4. (a) Explain the formation of fringes by transmission grating. (5 marks)
- (b) Describe how the wave lengths of monochromatic light can be measured using a diffraction grating and a spectrometer. (7 marks)
- (c) Explain why an oil layer on water surface appears coloured on rainy day. (3 marks)
- (d) Explain.  
(i) What is meant by plane polarized light. (2 marks)  
(ii) One application of polarized light. (3 marks)

### SECTION C

5. (a) Define magnetic flux linkage and its state its S.I unit. (2 marks)
- (b) (i) Describe an absolute method of determining resistance. (5 marks)  
(ii) State limitations of the above experiment in (5) (b) (i) (2 marks)
- (c) Describe how hall voltage is formed. (4 marks)
- (d) A coil of 50 turns and radius 4cm is placed with its plane in the earth's magnetic, meridian: A compass needle is placed at the centre of the coil. When the current of 0.1A passes through the coil, the compass needle deflects through  $40^\circ$ . When the current is reversed the needle deflects through  $43^\circ$  in opposite in the opposite direction. Calculate.  
(i) The horizontal component of the earth's flux density. (4 marks)

- (ii) The magnetic flux density of the earth at that place given that the angle of dip at the place is  $40^\circ$ . (3 marks)
6. (a) State the laws of electromagnetic induction. (2 marks)
- (b) Describe a method of measuring the magnetic flux density in region between the poles of a magnet by using search coil. (5 marks)
- (c) Two infinitely long straight wires carrying currents  $I_1$  and  $I_2$  respectively are placed parallel to each other in a vacuum at a distance  $d$  metres apart. Derive an expression for force per metre between the wires. (5 marks)
- (d) A wire of length  $7.85\text{m}$  is wound into a circular coil of radius  $0.05\text{m}$ . if a current of  $2\text{A}$  passes through the coil, find the magnetic flux density of the centre of the coil. (4 marks)
- (e) Describe one application of eddy currents. (4 marks)
7. (a) (i) Describe the structure and mode of operation of d.c motor. (3 marks)
- (ii) Describe the importance of back e.m.f in d.c motor. (2 marks)
- (b) (i) What is meant by sinusoidal alternating current? (1 mark)
- (ii) Define frequency of A.C. (1 mark)
- (c) Explain why a capacitor in a circuit blocks the flow of d.c but allows the flow of A.C. (3 marks)
- (d) A coil is connected across bulb A as shown in Figure 1.

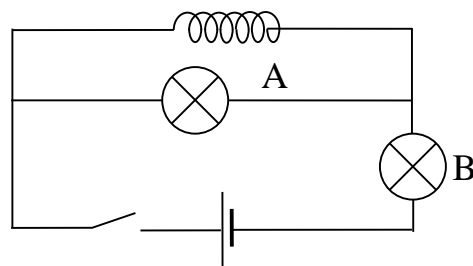

**Figure 1**

- Explain what will be observed when switch K is closed. (4 marks)
- (e) (i) A circuit consists of capacitor of  $2\mu\text{F}$  and a resistor of  $1000\Omega$ . An alternating e.m.f of  $12\text{V}$  and frequency  $50\text{Hz}$  is applied. Find the current flowing through  $1000\Omega$ . (3 marks)
- (ii) Explain why moving coil metres cannot measure A.C. (3 marks)

8. (a) (i) Define electrical resistivity of a conductor. (1 mark)  
(ii)

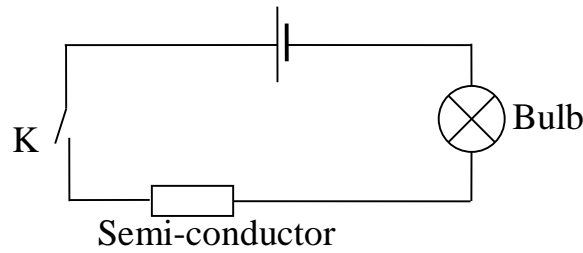

Figure 2

Figure 2 shows a battery connected in series with a semi-conductor and the bulb. State and explain what will be observed when K is closed.

(4 marks)

- (b) Describe an experiment to determine internal resistance of a cell by using volt meter, ammeter and resistance box. (4 marks)
- (c) (i) Drive expression for electrical power produced in a resistor of resistance R and P.d across it is V. (3 marks)  
(ii) Explain why standard resistors are made out of alloys like constantan. (1 marks)
- (d) In an experiment with a meter bridge the resistance R is kept in the left hand gap and fixed resistance Rs in the right hand gap. The resistance R is gradually heated. When its temperature is 30°C, the balanced point was 51.5cm from the left hand side of the slide wire. When its temperature was increased to 100°C, the balanced point was found to be 54.5cm from the right hand side. Find  
(i) the ratio of resistances of R at 30°C and 100°C. (4 marks)  
(ii) temperature coefficient of resistance. (3 marks)

9. (a) (i) Define electro motive force of battery. (1 mark)  
(ii) Describe an experiment to determine very small e.m.f by using potentiometer. (5 marks)

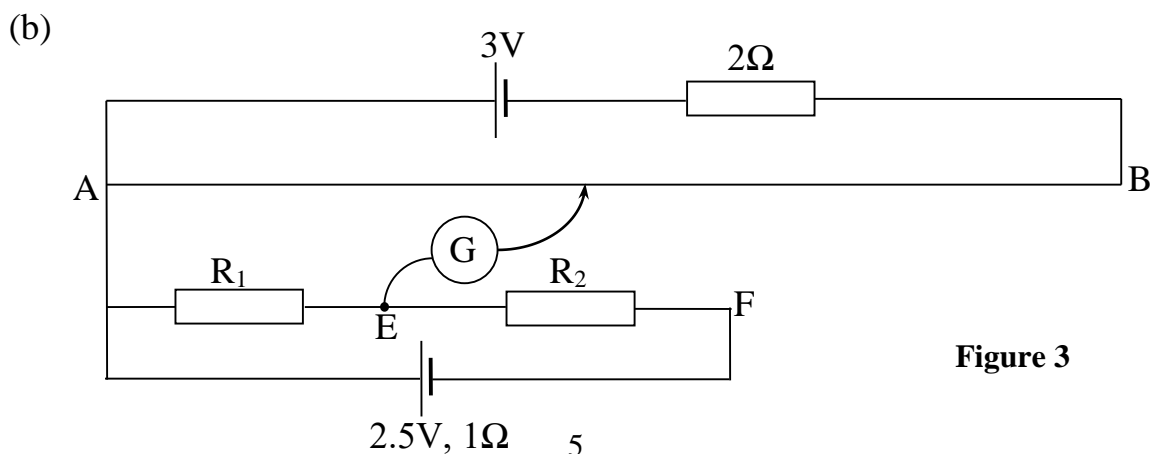

Figure 3

In the Figure 3 above, AB is a slide wire of length 1m and resistance  $10\Omega$ . X is a driver cell of e.m.f 3.0V and negligible internal resistance. When a galvanometer is connected to point E the balance length is 45cm. If the galvanometer is connected to F the balance length is 80cm. Calculate.

- (i) Current through  $R_1$  (4 marks)
  - (ii) Resistances of  $R_1$  and  $R_2$ . (3 marks)
- (c) State advantages of potentiometer over wheat stone bridge in determining resistance. (2 marks)
- (d) A battery of internal resistance  $3\Omega$  and e.m.f 18V is connected to a resistor R. If the battery is 73% efficient. Find.
- (i) value of R (3 marks)
  - (ii) Power generated (2 marks)
10. (a) (i) Define electric potential difference. (1 mark)
- (ii) Derive expression that connects electric potential difference and electric field intensity. (3marks)
- (b) (i) What is meant by charge quantization. (1 mark)
- (ii) A proton is fired from infinity with a speed of  $3.7 \times 10^6 \text{ms}^{-1}$  towards a stationery charge of  $+5e$ . Calculate the speed of proton at a point  $10^{-12}\text{m}$  from the stationery charge (Assume mass of proton =  $1.67 \times 10^{-27}\text{kg}$ ) and proton charge is  $+1\text{C}$ ). (4 marks)
- (c) Define dielectric strength. (1 mark)
- (d) A parallel plate capacitor is charged to 150V. When a sheet of dielectric is inserted between its plate, the p.d decreases to 50V.
- (i) Explain why there is change in the charge. (3 marks)
  - (ii) Calculate the dielectric constant of the sheet. (3 marks)
- (e) Describe how the unknown capacitance of a capacitor can be determined by using reed switch. (4 marks)

**END**